

■ Features

- ◆ High output power of 70W
- ◆ 400μm/0.22NA multimode optical fiber
- ◆ Center wavelength 520±10nm

■ Applications

- ◆ Scientific Research
- ◆ Lighting
- ◆ Medical Application

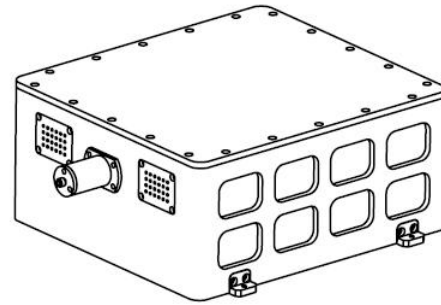

Outline Dimension (mm)

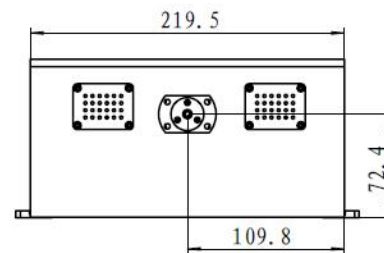
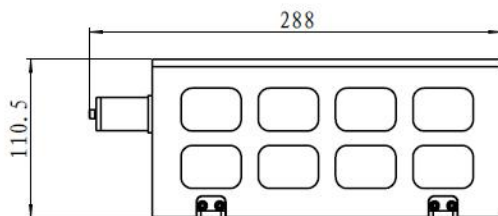

Pin-out Assignment			
Pi	Funcio	Pin	Function
1	LD1(+)	13	LD7(+)
2	LD1(-)	14	LD7(-)
3	LD2(+)	15	LD8(+)
4	LD2(-)	16	LD8(-)
5	LD3(+)	17	LD9(+)
6	LD3(-)	18	LD9(-)
7	LD4(+)	19	Thermistor
8	LD4(-)	20	Thermistor
9	LD5(+)	21	Indicating light (+5v)
10	LD5(-)	22	Indicating light (0v)
11	LD6(+)	23	PD(N)
12	LD6(-)	24	PD(P)

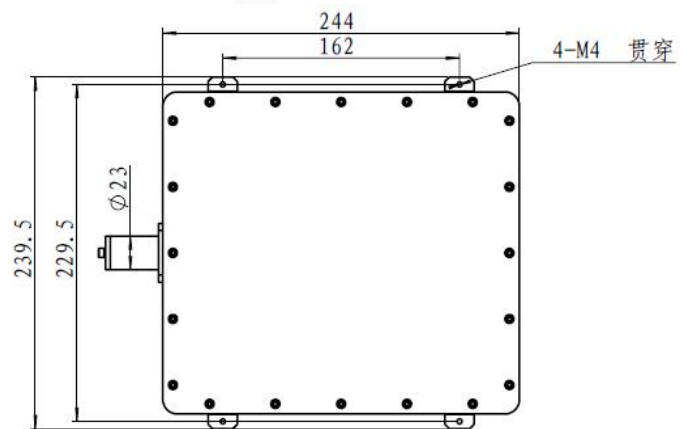

Typical Device Performance (20°C)

	Min	Typical	Max	Unit
Optical				
CW Output Power	-	70	-	W
Center Wavelength	-	520±10	-	nm
Spectral Width (90% of Power)	-	4.0	-	nm
Electrical*				
Threshold Current	-	-	0.50	A
Operating Current (Simplex)	-	4	4	A
Operating Voltage (Simplex)	-	20	-	V
Indicating light				
Output Power	-	2	-	mW
Center Wavelength	-	650±10	-	nm
Operating Current	-	<30	-	mA
Operating Voltage	-	5	-	V
Fiber*				
Fiber Core Diameter	-	400	-	μm
Numerical Aperture	-	0.22	-	-
Fiber Length	-	1-5	-	m
Fiber Connector	-	FC/SMA905	-	-
Fiber Armor	-	Optional	-	-
Fiber Minimum Bending Diameter	75	-	-	mm

The power supply mode of the laser has nine power supplies. Refrigeration method water cooling.

Absolute Rating

	Min	Max	Unit
Operating Temperature	15	35	°C
Operating Relative Humidity	-	75	%
Storage Temperature	-20	80	°C
Storage Relative Humidity	-	90	%
Lead Soldering Temperature (10 s max)	-	250	°C

* Measuring specifications.

All figures in this specification are measured by CNI's method and may contain measurement deviations.

The above specifications are for reference purpose only and subjected to change without prior notice.



Changchun New Industries Optoelectronics Tech. Co., Ltd
<http://www.cnilaser.com>

◆ CONTACT

No.888, JinHu Road, High-tech zone, Changchun
 130103, R.P. China

Phone: 0086-431-85603799

Fax: 0086-431-87020258