

MGL-W-532/15~20W



LD PUMPED ALL-SOLID-STATE GREEN LASER

All solid state 532nm green laser is made features of ultra compact, long lifetime and easy operating, which is widely used in collimation, laser medical treatment, scientific experiment, optical instrument, laser display, laser lighting show, etc.



SPECIFICATIONS

Model	MGL-W-532
Wavelength (nm)	532±1
Operating mode	CW
Output power (W)	>15, 16, 17, ..., 20
Power stability (rms, over 4 hours)	<1%, <2%, <3%, <5%
Transverse mode	Near TEM ₀₀
M ² factor	3~6
Beam divergence, full angle (mrad)	<2.0
Beam diameter at the aperture (1/e ² , mm)	~4.0
Warm-up time (minutes)	<10
Polarization ratio	>50:1(>100:1 optional)
Beam height from base plate (mm)	93.5
Operating temperature (°C)	10~35
Power supply (90-264VAC)	PSU-W-LED/PSU-W-FDA
TTL / Analog modulation	TTL or Analog with 1Hz-1kHz 1kHz-10kHz, 10kHz-30kHz optional
Expected lifetime (hours)	10000
Warranty period	1 year

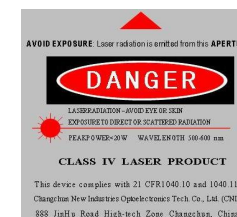

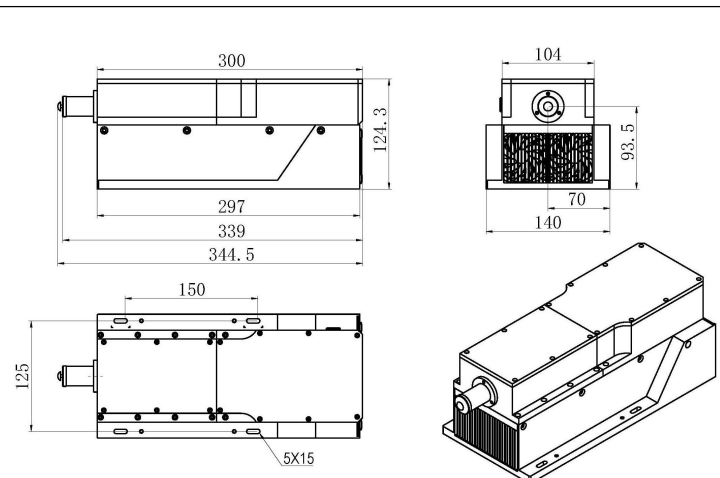
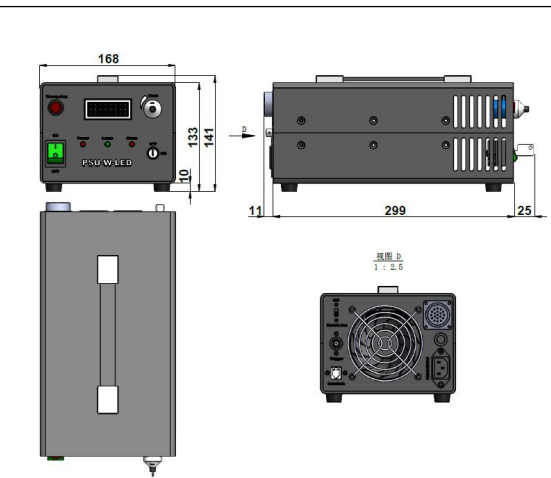
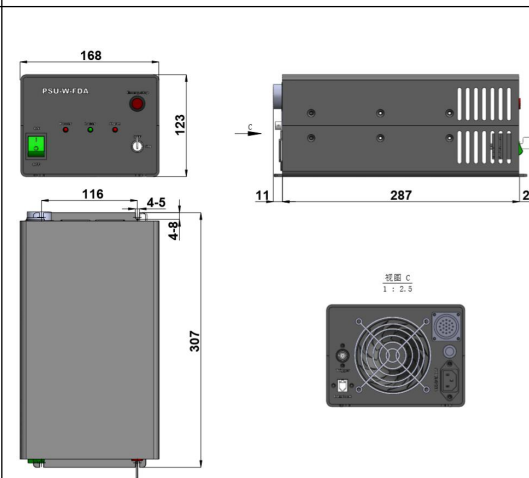
MGL-W-532	PSU-W-LED	PSU-W-FDA
 <p>344.5 (L) × 140 (W) × 124.3 (H) mm³, 5.7 kg</p>	 <p>335 (L) × 168 (W) × 133 (H) mm³, 4.2 kg</p>	 <p>323 (L) × 168 (W) × 123 (H) mm³, 4.1 kg</p>