

SPECIFICATIONS

Model	SM-1
Installation Interface	M22 × 1.5
Expansion Length	90+109+616+52+500+52+52+52=1523
Wavelength Range	1064nm
Optical path deviation	±0.3
Number of joints	7
Reflector Mirror size	Φ25 × 3
Maximum Optical aperture	Φ17
Reflectivity	1064nm ≥ 99.6%, 532nm ≥ 98%

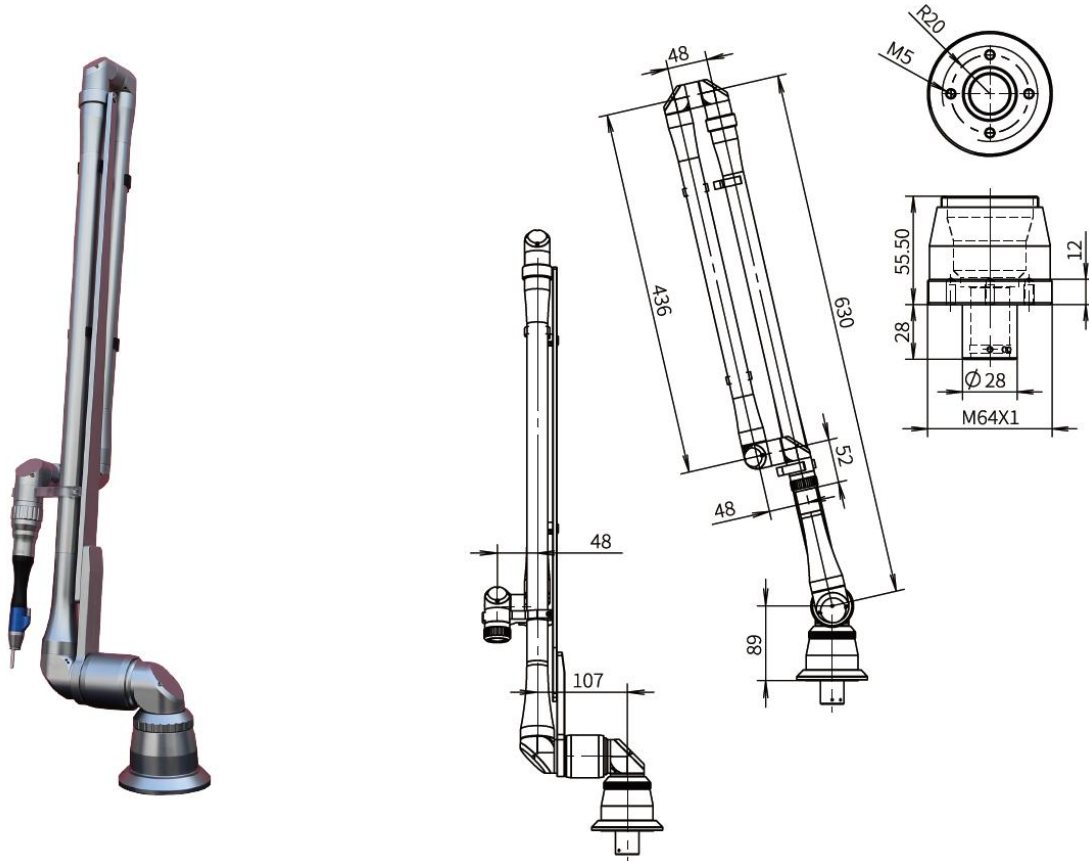

SPECIFICATIONS

Model	SM-2
Installation Interface	M20×1
Expansion Length	89+107+630+48+436+48+48+52=1458
Wavelength Range	10.6um
Optical path deviation	±0.3
Number of joints	7
Reflector Mirror size	Φ25×3
Maximum Optical aperture	Φ17
Reflectivity	10.6um ≥98%