



AO-532A-LM 8W /10W



LD PUMPED ALL-SOLID-STATE
AOM Q-SWITCHED LASER

All solid state AOM Q-switched laser at 532 nm has the features of high peak power, high repetition rate, and short pulse duration, which is in marking on materials that are hard, such as highly reflective metals: silver and gold; semiconductors: including silicon, gallium arsenide and germanium, and rubbers such as silicone.



SPECIFICATIONS

Wavelength (nm)	532±1	
Operating mode	Acousto-Optic Q-switched	
Average power (W)	8W@30kHz	10W@30kHz
	Average power (W) = Single pulse energy (mJ) * Rep. rate (kHz)	
Single pulse energy (μJ)	>260μJ @30kHz	>330μJ @30kHz
Rep. rate (kHz)	20~200	
Pulse width (ns)	~13 @30kHz	~12 @30kHz
Transverse mode	TEM ₀₀	
Beam Circularity (%)	>90	
Beam quality (M ²)	<1.2	
Beam divergence, full angle (mrad)	<0.2	
Beam diameter at the aperture (mm)	8±1	
Polarization ratio and Direction	>100:1, Vertical	
Beam height from base plate (mm)	79	
Warm-up time (minutes)	<10	
Cooling method	Air Cooled	
Environment temperature (°C)	10~35	
Supply Voltage	DC 12V/25A (optional)	

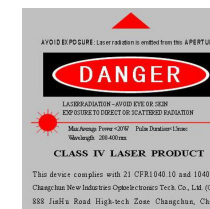

AO-532A-LM *Integrated electronics*

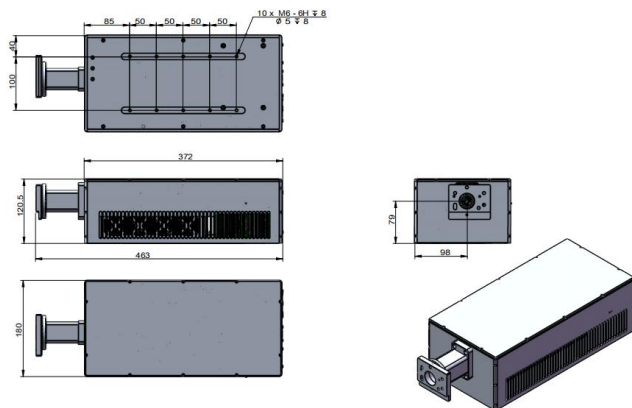

463(L) ×180 (W) ×120.5 (H) mm³, 9.6 kg

Power supply 100-240VAC

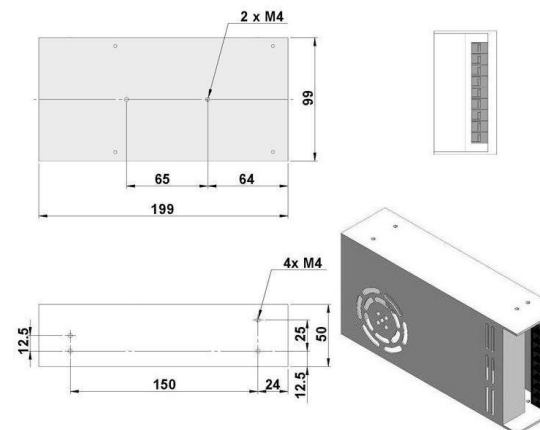

DC12V 25A; 199 (L) ×99 (W) ×50 (H) mm³, 0.9 kg